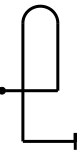
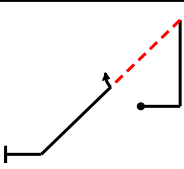
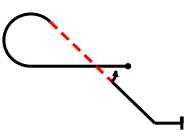
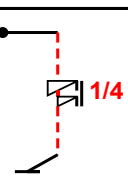
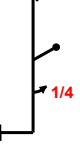
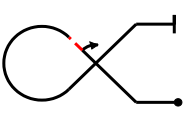
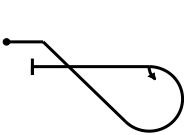
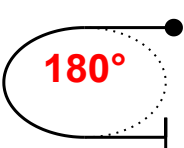
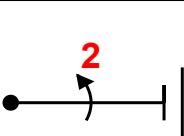

Pilot ID

AAC Sportsman Known

Flight #

No	Symbol	Cat. No.	K	Total K	Grade	Pos	Remarks	Item	K	Grade
1		8.4.1.1	13	13	.			Pos.	15	
								Harm.	0	
2		1.2.7.1 9.1.4.2	13 4	17	.			Fig K	Total K	
								133	148	
3		8.5.6.1 9.1.4.2	10 4	14	.			Penalties		
								Too Low		
								Too High		
								Interruptions		
								Insertions		
								Trg Violation		
								Wing Rocks		
Disqual Fig										
Other(note...)										
5		1.1.6.3 9.11.1.5	10 4	14	.			Final Freestyle		
								Duration	Min	Sec
6		5.2.1.1 9.1.5.1	17 2	19	.			Judges Details		
								Signature		
7		7.3.2.1 9.1.2.2	14 6	20	.			Name		
								Number		
8		8.5.3.3 9.1.3.2	10 4	14	.					
9		2.2.1.1	4	4	.					
10		1.1.1.1 9.2.3.4	2 9	11	.					

Pilot

A/C

← wind/vent

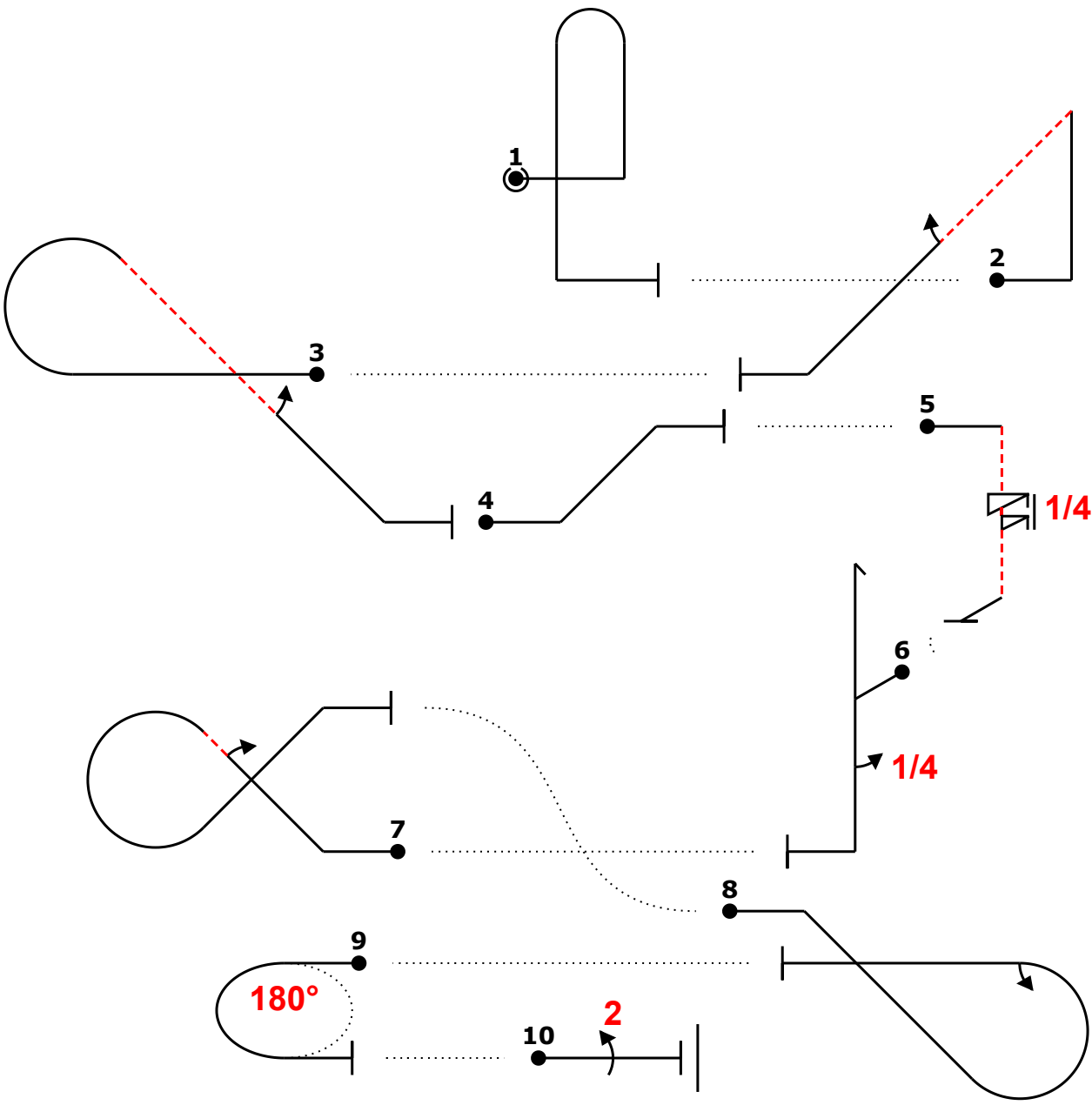

Power			
Fig	Aresti	K	
1	8.4.1.1	13	13
2	1.2.7.1 9.1.4.2	13 4	17
3	8.5.6.1 9.1.4.2	10 4	14
4	1.1.2.1	7	7
5	1.1.6.3 9.11.1.5	10 4	14
6	5.2.1.1 9.1.5.1	17 2	19
7	7.3.2.1 9.1.2.2	14 6	20
8	8.5.3.3 9.1.3.2	10 4	14
9	2.2.1.1	4	4
10	1.1.1.1 9.2.3.4	2 9	11
Total K = 133			

Pilot
A/C

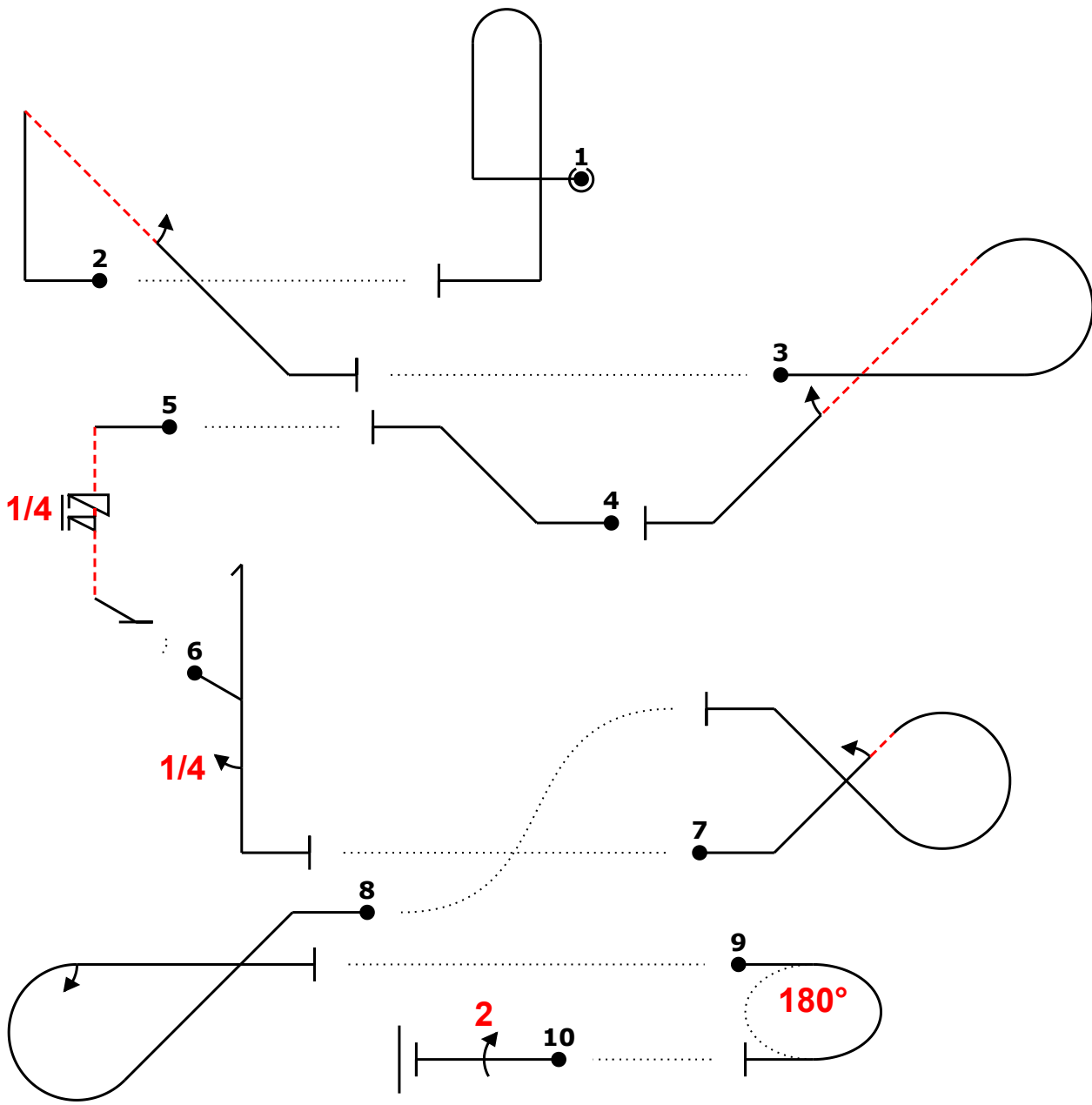
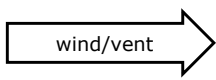

Power			
Fig	Aresti	K	
1	8.4.1.1	13	13
2	1.2.7.1 9.1.4.2	13 4	17
3	8.5.6.1 9.1.4.2	10 4	14
4	1.1.2.1	7	7
5	1.1.6.3 9.11.1.5	10 4	14
6	5.2.1.1 9.1.5.1	17 2	19
7	7.3.2.1 9.1.2.2	14 6	20
8	8.5.3.3 9.1.3.2	10 4	14
9	2.2.1.1	4	4
10	1.1.1.1 9.2.3.4	2 9	11
Total K = 133			

